



# *Tidal/Wave*

PAF PUMP SERIES

## Operating Manual

Includes Pumps:

PAF-20SV

PAF-25SV

PAF-40SV

PAF-75SV



1-877-80-PONDS  
[www.atlanticwatergardens.com](http://www.atlanticwatergardens.com)

## Introduction

Thank you for selecting the Tidal Wave PAF-20SV/PAF-25SV/PAF-40SV/PAF-75SV series pumps. Before using this pump please take a moment to review this manual.

To avoid an accident do not use the pump in any way other than as described in this manual. Please note the manufacturer cannot be responsible for accidents arising because the product was not used as prescribed. After reading this manual keep it as a reference in case questions arise during use.

### Performance: PAF Pump Series

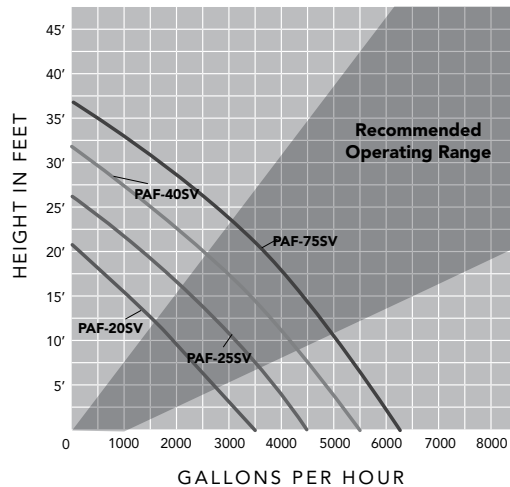

	PAF-20SV	PAF-25SV	PAF-40SV	PAF-75SV
Amps	3.5	5	6	8.5
Discharge Size	2"	2"	2"	2"
Weight	12 lbs.	13 lbs.	16 lbs.	19 lbs.
Motor HP	1/4	1/3	1/2	1
G P H A T H E A D H E I G H T				
5'	2800	3900	4950	5950
10'	1950	3150	4350	5270
15'	1080	2300	3570	4560
20'	180	1350	2700	3750
25'	0	240	1700	2830
30'	0	0	520	1770
35'	0	0	0	550

## Prior to Operation and Installation

- When the pump is delivered, first perform the following checks.
- Check for any damage to pump and power cable that may have occurred during the shipment.
- Check the model number to make sure it is the product that was ordered and verify the voltage and frequency are correct.

## Caution

- DO NOT operate this product under any condition other than those for which it is specified. Failure to observe this precaution can lead to electrical shock, electrical leakage, fire, water leakage or other problems.
- The pump is a 100/120 volt 60 Hz pump, please only use with a power supply voltage within 100-120 volt 60 Hz.
- DO NOT apply any paint over the stainless steel motor body. Reduced cooling ability will result in overheat, overload, introduce undesirable performance reductions, periodic auto shut-off and pump malfunction.
- Never place your hand or any object in or near the inlet opening while this equipment is operating. If pump inlet is clogged, always turn off the power supply, fuse box or circuit breaker and wait until the motor is completely stopped before attempting to remove any clogged material.
- Please make sure that the power plug and the AC outlet receptacle is protected and away from water or pump discharge hose to prevent accidental electric shock or short circuit.
- Always operate the pump completely submerged in water.
- Avoid dry operation, which will not only lower performance but can cause the pump to overheat/malfunction, leading to electrical leakage, shock or premature failure.
- **CAUTION:**  
THIS PUMP IS TO BE USED IN A CIRCUIT PROTECTED BY A GROUND CIRCUIT INTERRUPTER.
- **ATTENTION:**  
CETTE POMPE DOIT ETRE BRANCHEE A UNE DERIVATION PROTEGEE PAR UN DISJONCTEUR DIFFERENTIEL.
- **CAUTION:**  
THIS PUMP HAS BEEN EVALUATED FOR USE IN WATER ONLY.
- **WARNING:**  
RISK OF ELECTRIC SHOCK - THIS PUMP IS SUPPLIED WITH A GROUNDING CONDUCTOR AND GROUNDING-TYPE ATTACHMENT PLUG. TO REDUCE THE RISK OF ELECTRIC SHOCK, BE CERTAIN THAT IT IS CONNECTED ONLY TO A PROPERLY GROUNDED, GROUNDING TYPE RECEPTACLE.

## Before You Start

- Check the model name plate to make sure once again that the product is of the correct voltage and frequency rating.
- The setting on the circuit breaker or other overload protector should be made in accord with the rated current of the pump.
- Turn off the power supply or circuit breaker before inserting the power supply plug to avoid electrical shock, shorting, or unexpected starting of the pump, which could lead to injury.
- Never operate the pump while it is suspended in air. The recoil may result in injury or other major accident.

## Electrical Safety

- Electrical wiring should be installed by a qualified electrician in accordance with all applicable safety regulations. Incorrect wiring can lead to a pump malfunction, electrical shock or fire.
- Pumps should operate on a designated, 110 volt circuit rated at 15 Amps (minimum).
- Pump must be protected by a ground fault circuit interrupter (GFCI).
- Pump must be plugged into a standard, properly grounded, three pronged outlet.
- Do not cut the electrical cable. If a cable with cut insulation or other damage is submerged in water, there is danger of water seeping into the pump motor and causing a short. This may result in damage to the pump, electrical shock or fire. **Altering the electrical cable in any way will void the warranty.**
- Never move or handle the pump by pulling on the electrical cable. Make sure the electrical cable does not become excessively bent or twisted, does not rub against a structure in a way that might damage it, and does not come in contact with heated surfaces.

## Operation

- In case of a power outage, turn off the power to the pump to avoid having it start unexpectedly when the power is restored.
- Pay careful attention to the water level while the pump is operating. Dry operation may cause the pump to malfunction. Pump must always operate while fully submerged.

- In case of very excessive vibration, unusual noise or odor, turn off the power immediately and consult with your nearest dealer. Continuing to operate the pump under abnormal conditions may result in electrical leakage, electrical shock or fire.

## Motor Protection System

- The pump has a built-in motor protection system. The following reasons may cause the pump to stop automatically regardless of water level.
  - ▶ Motor overheating
  - ▶ Excessive current
  - ▶ Change in voltage polarity
  - ▶ Open-phase operation or operation under constraint
- Repeating cycles of stopping and restarting will damage the water pump. Do not continue operation at low lift, low water level, or while the inlet is clogged with debris. Not only will performance suffer, but also such conditions may cause noise, heavy vibration, and pump failure.

## Maintenance and Inspection

- Regular maintenance and inspections are a necessity for continued efficient functioning. If any abnormal conditions are noticed, refer to the section on Troubleshooting and take corrective measures immediately.
- During or after the warranty period, the customer is NOT to disassemble the pump for any reason.

## Monthly Inspection

- Check for any drop in performance. Reduced performance is usually caused by debris blocking the intake screen.
- Detach the power cable from the receptacle and turn off the power supply (circuit breaker).
- Disconnect the pump discharge and remove the pump from the water.
- Remove any accumulated debris from the surface of the pump, inlet screen and impeller.
- Make sure all nuts and bolts are fastened securely.
- Do not disassemble the pump for any reason. Disassembly will void the pump warranty. Refer operating and maintenance problems to a qualified technician.

## Winterizing

- Under no circumstances should the pump be left in frozen water.
- When the pump is out of use for an extended period, wash it and dry it thoroughly, then store it indoors.

**Note:** Always run a test operation before putting the pump back into operation. When the pump is left installed in water it should be run at regular intervals (about once per week).

## Warranty

All Tidal Wave Pumps carry a two year limited warranty. This limited warranty is extended solely to the original purchaser commencing from the date of original purchase receipt and is void if any of the following apply:

- The pump has been run while not fully submersed causing the thermal protection to trip. Skimmers using inadequate vertical filtration may create "run dry" conditions.
- The pump was not run on a dedicated circuit.
- The cord has been cut or altered.
- The pump has been misused or abused.
- Serial number tag has been removed.
- The pump has been fully or partially disassembled.

## Warranty Claims

- In case of warranty claims, pump should be returned to place of purchase accompanied by original receipt.

NO.	Description
1	Handle
2	Pump Cover
3	Condenser
4	Packing
5	Motor Cover
6	Ball Bearing (upper)
7	Thermal Protection
8	Motor Cover
9	Shaft
10	Motor Case
11	Ball Bearing (Lower)
12	Motor Base
13	Packing
14	Mechanical Seal
15	Pump Base
16	Impeller
17	Packing
18	Pump Case
19	Filter

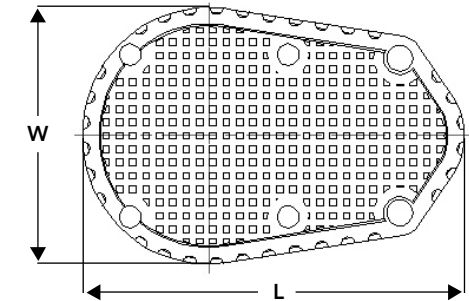
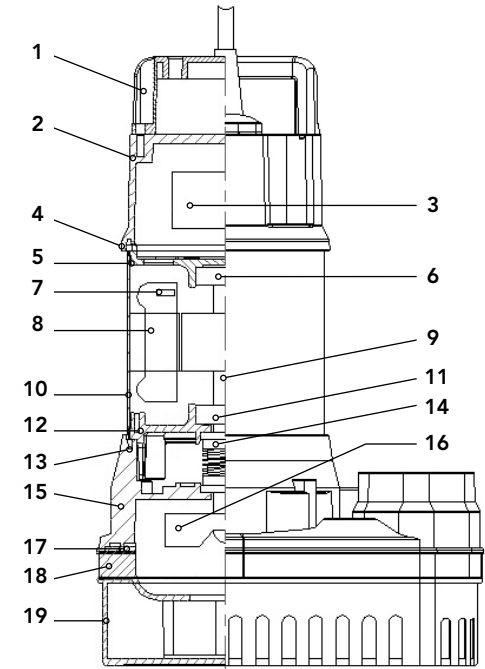

	PAF-20SV	PAF-25SV	PAF-40SV	PAF-75SV
Length	9 1/4"	9 1/4"	9 1/4"	9 1/4"
Width	6 1/8"	6 1/8"	6 1/8"	6 1/8"
Height	14"	14 1/2"	15"	16"

# Troubleshooting Guide

Always turn off power before inspecting the pump. Failure to observe this precaution can result in a serious accident.

Before ordering repairs, carefully read through this instruction booklet. If the problem persists, contact your dealer.

Problem	Possible Cause	Possible Solution
Pump does not start	Power is off	Turn power on
	Power failure	Check power supply or contact local power company
	Voltage drop/ Overload	Check/Replace the GFI (Ground Fault Interrupter)
	Power cord is not connected	Connect power cord
Pump stops after starting	Pump is overheating	Submerge pump/Raise water level/ Allow pump to cool
	Power/Current overload	Check length/size of power cable. Check or replace GFI
	Impeller is blocked	Remove debris from the impeller chamber
Diminished flow rate or no water flow	Air lock	Restart/Clean air valve
	Obstruction in pump or piping	Clear obstruction
	Piping is too long	Reduce length of pipe



1-877-80-PONDS  
www.atlanticwatergardens.com